

ANSI 150# RF Duplex Basket Strainer Flat Basket Style

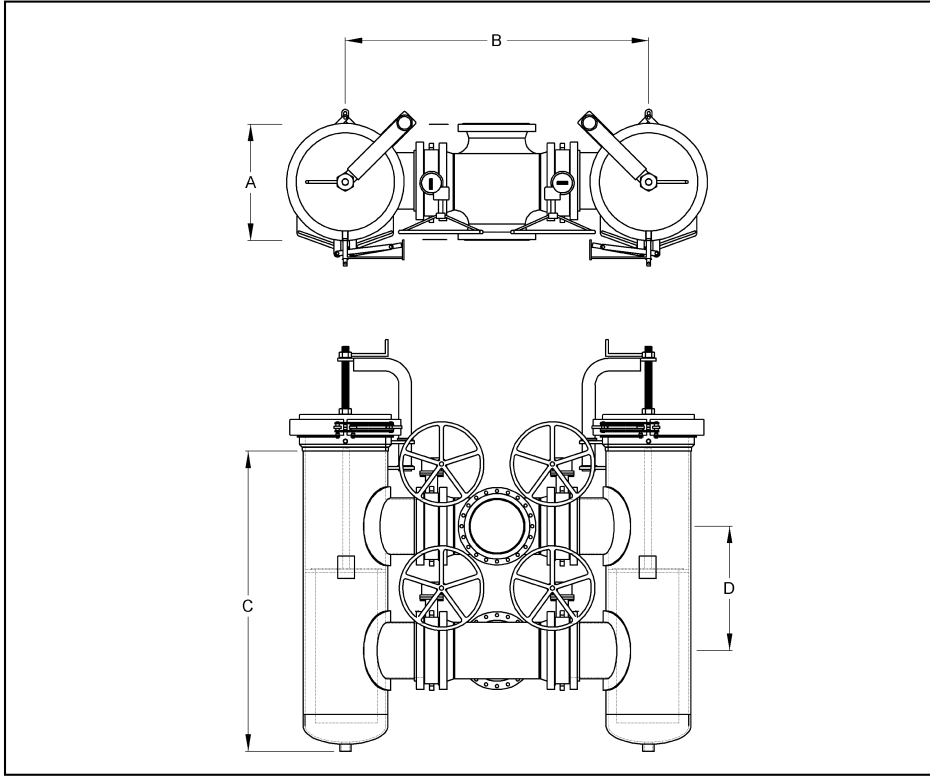

Standard Feature

- Bolted access cover c/w NAF gasket
- Swing bolt syle closure c/w Buna N O-Ring seal
- 1/8" Perforated Stainless Steel (304) Basket
- 1/2" NPT Vent, NPT Drain

Line Size	Body Dia	A	B	C	D	Drain NPT	Weight Bolted	Cover Weight
2	4.50	10.25	29.5	14	8	3/4	200	17
3	6.625	12.5	33	18	9	3/4	360	26
4	8.825	14.5	36.5	24	12	3/4	550	45
6	10.75	18.5	45	36	18	1	890	70
8	12.75	22.25	53	46	20	1	1420	110
10	14	25.25	60.25	54	24	1	2025	140
12	16	29.25	68.25	66	30	1 1/2	2830	180
16	20	34.25	82	74	36	1 1/2	4410	285